

REP.	CODE_ARTICLE	DESIGNATION 1	ERP /QT E
1	E05000046	ARBRE ENTRAINEMENT DR160 NU	1
2	E03001344	AXE A PATTE COURTE BICH 30X105	1
3	E03000013	AXE A PATTE COURTE BICH 30X120	2
4	E03001460	AXE A PATTE COURTE BICH 30X75	1
5	C12000134	AXE ATTELAGE BICH 3°PT Ø25.4X120	1
6	D02000788	AXE COUDE BICH 16X165	2
7	C02000002	BAGUE PAF 16120 P10	2
8	C02000025	BAGUE TY 30 X 34 X 25	3
9	E03000050	BARETTE DR160 2DTS ETROITES	6
10	E03000051	BARETTE DR160 2DTS LARGE	6
11	E03000052	BARETTE DR160 3DTS	7
12	E03000048	BARRE ATTELAGE DR160P-DR200P-DT120 Ø40	1
13	E07000028	BASE COMMUNE MOTEUR DR	1
14	G02000051	BOUCHON AILETTE 120X80X5	2
15	G02000014	BOUCHON CARRE A AILETTE 40X40X1-3	2
16	G02000021	BOUCHON ROND AILETTE Ø40 NOIR	2
17	G02000025	BOUCHON ROND AILETTE Ø60 NOIR	2
18	E02000304	BRAS DE CHARG NU - DR200	1
19	E03000059	BUTEE DR160	1
20	C10000028	CHAINE 15.8 45 MAILLONS + A.R.	1
21	C10000050	CHAINE S62 77 MAILS K1C-4P-2C-ME-DR +AR	2
22	C08000465	CHAPE MALE A OEIL M10 ZN	2
23	E01000771	CHASSIS NU DR200P HYDR.	1
24	D01002636	DECOUPE LASER L923D EP.12	1
25	D02001471	DECOUPE LASER L940 EP.8 FRAISEE	1
26	D03000917	DECOUPE LASER L1316 EP.2 PLIEE	1
27	D03000708	DECOUPE LASER L1317 EP.2 PLIEE	1
28	D03000981	DECOUPE LASER L2190 EP.1.5	1
29	D01005248	DECOUPE LASER L1299 EP.3	1
30	C08000003	ECROU 934 CL 8 ZN 10 X 150	2
31	C08000004	ECROU 934 CL 8 ZN 12 X 175	4
32	C08000006	ECROU 934 CL 8 ZN 16 X 200	2
33	C08000031	ECROU FREIN 985 CL 8 ZN 10 X 150	32
34	C08000033	ECROU FREIN 985 CL 8 ZN 14 X 200	4
35	C08000043	ECROU FREIN 985 CL 8 ZN 6 X 100	4
36	C08000044	ECROU FREIN 985 CL 8 ZN 8 X 125	76
37	D02001579	ETIRE Ø 40 LG 19	2
38	E02000066	FOND MOBILE DR	1
39	C09000008	GOUPILLE CLIP 10MM	1
40	C09000009	GOUPILLE CLIP 4.5MM	2
41	C03000010	GRAISSEUR 6X100 STD + CHAPEAU PROTECT	4
42	B01000007	MOTEUR OMP 160	1
43	C04000005	PALIER APPLIQUE 35	2
44	E03001567	PIGNON MOTEUR ROTATION DR200P	1
45	C06000021	PIGNON SIMPLE 15 DTS 5-8 - Ø25+RC+VP	1
46	G02000027	POIGNEE BAKELITE FILETE 12X20	2
47	E02000002	RALLONGE DE BRAS DR160	1
48	C11000018	RESSORT TRACT 40 X 5.8 X 371	2
49	D02001292	ROND AVANT TRAIN Ø600 PERCE SYMETRIQ.	1
50	C08000087	RONDELLE PLATE ZN L 8	76
51	C08000079	RONDELLE PLATE ZN L10	2
52	C08000540	RONDELLE PLATE ZN M10	2
53	C08000121	RONDELLE PLATE ZN Z 6	4
54	C08000108	RONDELLE PLATE ZN Z10	6
55	E01000767	SUPPORT DR200 PIV. HYDR.	1
56	D01002696	TOLE EP. 1.5 DEBIT 595X560	1
57	D04000612	TUBE Ø 13X 1.5 LG 15	2
58	B05000107	UNION MALE 13G 1-2 GAZ CO NU	2
59	B02000129	VERIN DE 35X70C 330 EF510+CLAPET PILOTE	1
60	C08000735	VIS AUTOFOREUSE TH AC ZN 6.3X25	12
61	C08000177	Vis sans tête STHC 10.9NOIRE M6X10 BOUT PLAT	2
62	C08000174	Vis sans tête STHC 10.9NOIRE M8X10 BOUT PLAT	1
63	C08000720	VIS TFHC 7991 10.9 ZN 6 X 20	2
64	C08000307	VIS TH ISO 4014 ZN 10X45 8.8	2
65	C08000193	VIS TH ISO 4014 ZN 10X50 8.8	8
66	C08000257	VIS TH ISO 4014 ZN 6X65 8.8	4
67	C08000304	VIS TH ISO 4017 ZN 10X25 8.8	4
68	C08000305	VIS TH ISO 4017 ZN 10X30 8.8	9
69	C08000306	VIS TH ISO 4017 ZN 10X35 8.8	2
70	C08000310	VIS TH ISO 4017 ZN 12X30 8.8	4
71	C08000799	VIS TH ISO 4017 ZN 14X40 8.8	2
72	C08000684	VIS TH ISO 4017 ZN 16X60 8.8	2
73	C08000353	VIS TH ISO 4017 ZN 8X20 8.8	76
74	B06000231	LIMITEUR PRESSION DOUBLE 1-2 FLASQUABLE	1
75	C15000004	JOINT BS Ø17 3-8	6
76	B05000112	UNION MALE 13G 3-8 GAZ CYL NU	4
77	B05000005	ADAPTATEUR MALE AFE 13G 3-8 CYL	2
78	B06000248	CLAPET VNR ANTI RETOUR 3-8 PERCE A Ø0.6	2

Tolérances générales: ( sauf indications )  
débit +/- 1mm usinage +/- 0.1mm pliage +/- 1° assemblage +/- 1mm

**ALTEC** Plan N°: F06000214

Dess: LT1 Mat.: Traitement de surface:  
Date: Poids: 687.25kg Brut  
Format: A3

Désignation1:  
DR200PA+PH

Désignation2:  
DR200PA+PH

Code Article: F06000214

FEUILLE 1/1 Ech.: 1:22 Ind.: A

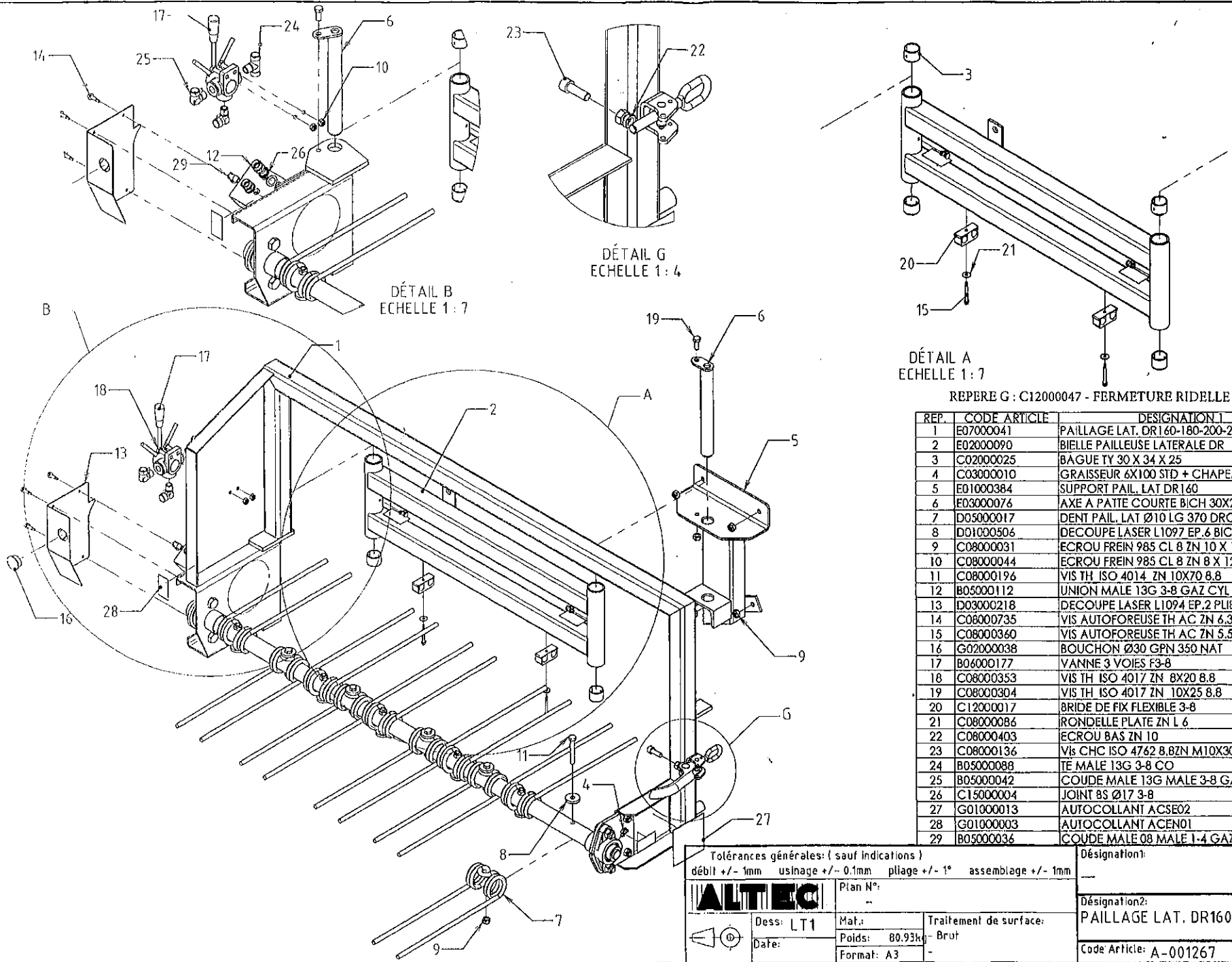

REPERE G : C12000047 - FERMETURE RIDELLE

REP.	CODE ARTICLE	DESIGNATION 1	QTY
1	E07000041	PAILLAGE LAT. DR160-180-200-280 EN NOIR	1
2	E02000090	BIELLE PAILLEUSE LATERALE DR	1
3	C02000025	BAGUE TY 30 X 34 X 25	4
4	C03000010	GRAISSEUR 6X100 STD + CHAPEAU PROTECT	4
5	E01000384	SUPPORT PAIL. LAT DR160	1
6	E03000076	AXE A PATTE COURTE BICH 30X255	2
7	D05000017	DENT PAIL. LAT Ø10 LG 370 DROITE	10
8	D01000506	DECOUPE LASER L1097 EP.6 BICH	10
9	C08000031	ECROU FREIN 985 CL 8 ZN 10 X 150	16
10	C08000044	ECROU FREIN 985 CL 8 ZN 8 X 125	2
11	C08000196	VIS TH ISO 4014 ZN 10X70 8.8	10
12	B05000112	UNION MALE 13G 3-8 GAZ CYL NU	2
13	D03000218	DECOUPE LASER L1094 EP.2 PLIEE STD	1
14	C08000735	VIS AUTOFOREUSE TH AC ZN 6.3X25	3
15	C08000360	VIS AUTOFOREUSE TH AC ZN 5.5X50	2
16	G02000038	BOUCHON Ø30 GPN 350 NAT	1
17	B06000177	VANNE 3 VOIES F3-8	1
18	C08000353	VIS TH ISO 4017 ZN 8X20 8.8	2
19	C08000304	VIS TH ISO 4017 ZN 10X25 8.8	2
20	C12000017	BRIDE DE FIX FLEXIBLE 3-8	2
21	C08000086	RONDELLE PLATE ZN L 6	2
22	C08000403	ECROU BAS ZN 10	1
23	C08000136	Vis CHC ISO 4762 8.8ZN M10X30	1
24	B05000088	TE MALE 13G 3-8 CO	1
25	B05000042	COUDE MALE 13G MALE 3-8 GAZ CO NU	2
26	C15000004	JOINT BS Ø17 3-8	2
27	G01000013	AUTOCOLLANT ACSE02	1
28	G01000003	AUTOCOLLANT ACEN01	4
29	B05000036	COUDE MALE 08 MALE 1-4 GAZ CO NU	1

Tolérances générales: (sauf indications)  
 débit +/- 1mm usinage +/- 0.1mm pliage +/- 1° assemblage +/- 1mm

**ALTEC** Plan N°: --

Dess: LT1 Mat.: -- Traitement de surface: Brut

Date: -- Poids: 80.93kg -

Format: A3

Désignation: PAILLAGE LAT. DR160-DR180

Désignation2: PAILLAGE LAT. DR160-DR180

Code Article: A-001267 FEUILLE 1/1 Ech: 1:8 Ind: A

POUR LES DEMANDES CONCERNANT LES PIGNONS  
OU LA CHAINE,  
MERCİ DE PRECISER LE NOMBRE DE DENTS OU LE  
NOMBRE DE MAILLONS

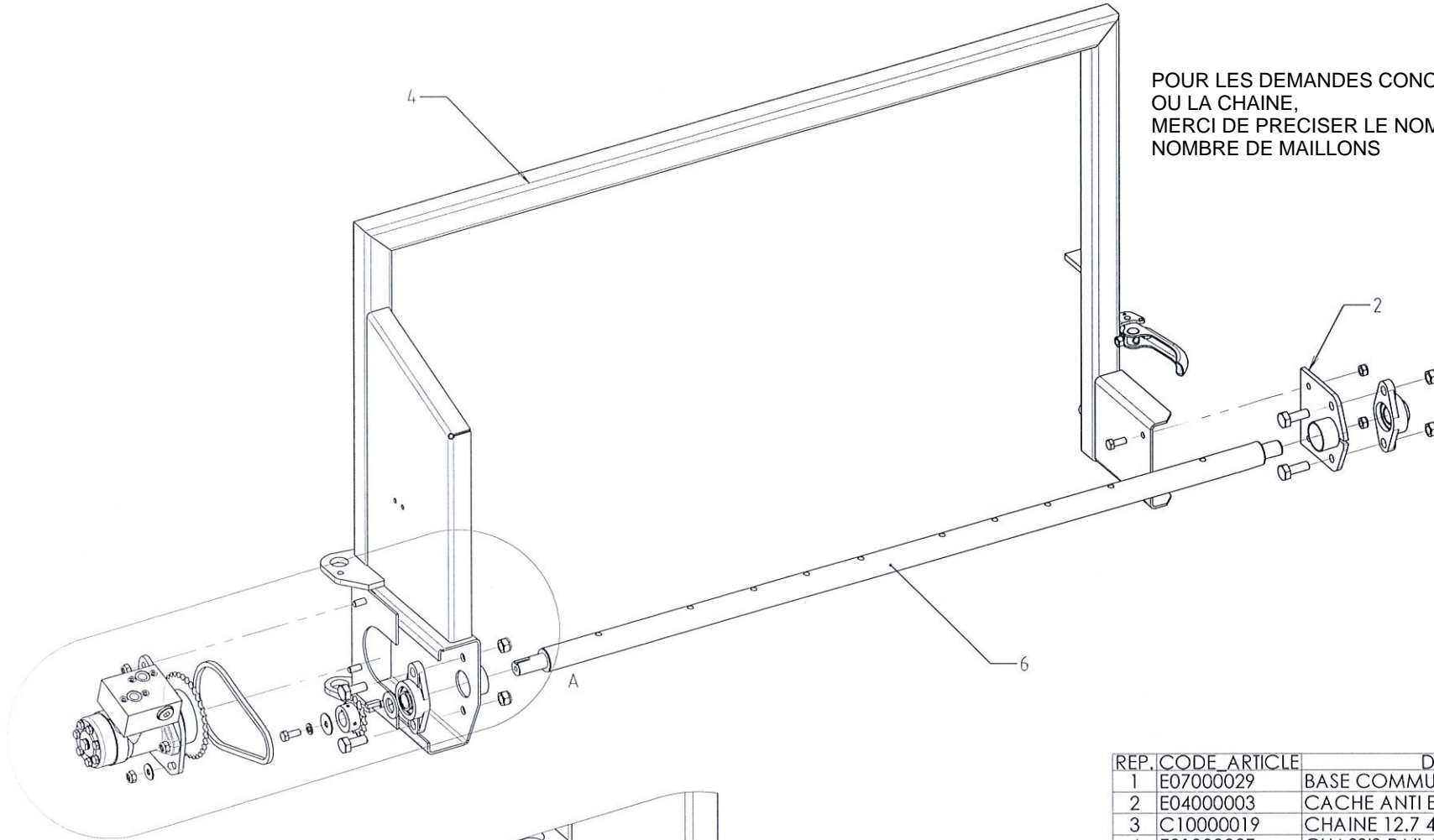

DÉTAIL A  
ECHELLE 1: 5

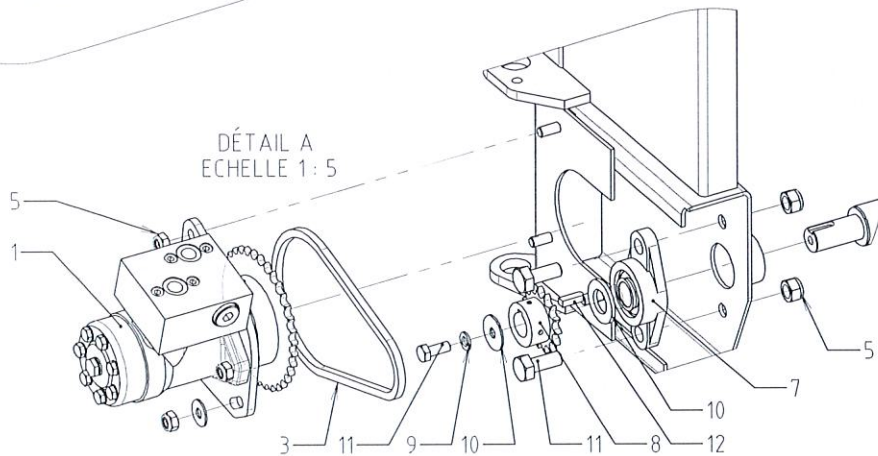

REP.	CODE_ARTICLE	DESIGNATION 1	QTE
1	E07000029	BASE COMMUNE MOTEUR PAIL LAT	1
2	E04000003	CACHE ANTI ENR PAIL LAT.	1
3	C10000019	CHAINE 12.7 47 MAILLONS+AR	1
4	E01000027	CHASSIS PAIL LAT DR - NU	1
5	C08000031	ECROU FREIN 985 CL 8 ZN 10 X 150	9
6	D02000733	ETIRE Ø 40 LG 1443	1
7	C04000003	PALIER APPLIQUE 25	2
8	C06000020	PIGNON SIMPLE 15 DTS 1-2 - Ø25+RC+VP	1
9	C08000055	RONDELLE GROWER 127 ZN 10	1
10	C08000115	RONDELLE PLATE ZN Z24	4
11	C08000304	VIS TH ISO 4017 ZN 10X25 8.8	7
12	C09000057	CLAVETTE BOUT ARRONDI-BOUT PLAT 8X7X25	1

Tolérances générales: ( sauf indications ) débit +/- 1mm usinage +/- 0.1mm pliage +/- 1° assemblage +/- 1mm			Désignation1: PAILLAGE LAT. DR160-180-200-280 EN NOIR
		Plan N°: E07000041	Désignation2: PAILLAGE LAT. DR160-180-200-280 EN NOIR
Dess: LT1	Mat.:	Traitement de surface:	Code Article E07000041
Date: 14-09-2018	Poids: 53.76kg	- Brut	
	Format: A3		Ech: 1:7 FEUILLE 1/1 Ind.: B

REP.	CODE_ARTICLE	DESIGNATION 1	QTE
1	D02000735	DECOUPE LASER L770B EP.8 FRAISEE	1
2	B01000004	MOTEUR OMP 80	1
3	C08000581	VIS TFHC 7991 10.9 ZN 10 X 40	2
4	C08000031	ECROU FREIN 985 CL 8 ZN 10 X 150	2
5	B06000100	BLOC FORE DOUBLE CLAPET ANTI- RETOUR	1
6	C08000161	Vis CHC ISO 4762 8.8ZN M8X50	4
7	C06000038	PIGNON SIMPLE 35 DTS 1-2 - Ø25+RC+VP	1
8	D04000612	TUBE Ø 13X 1.5 LG 15	2

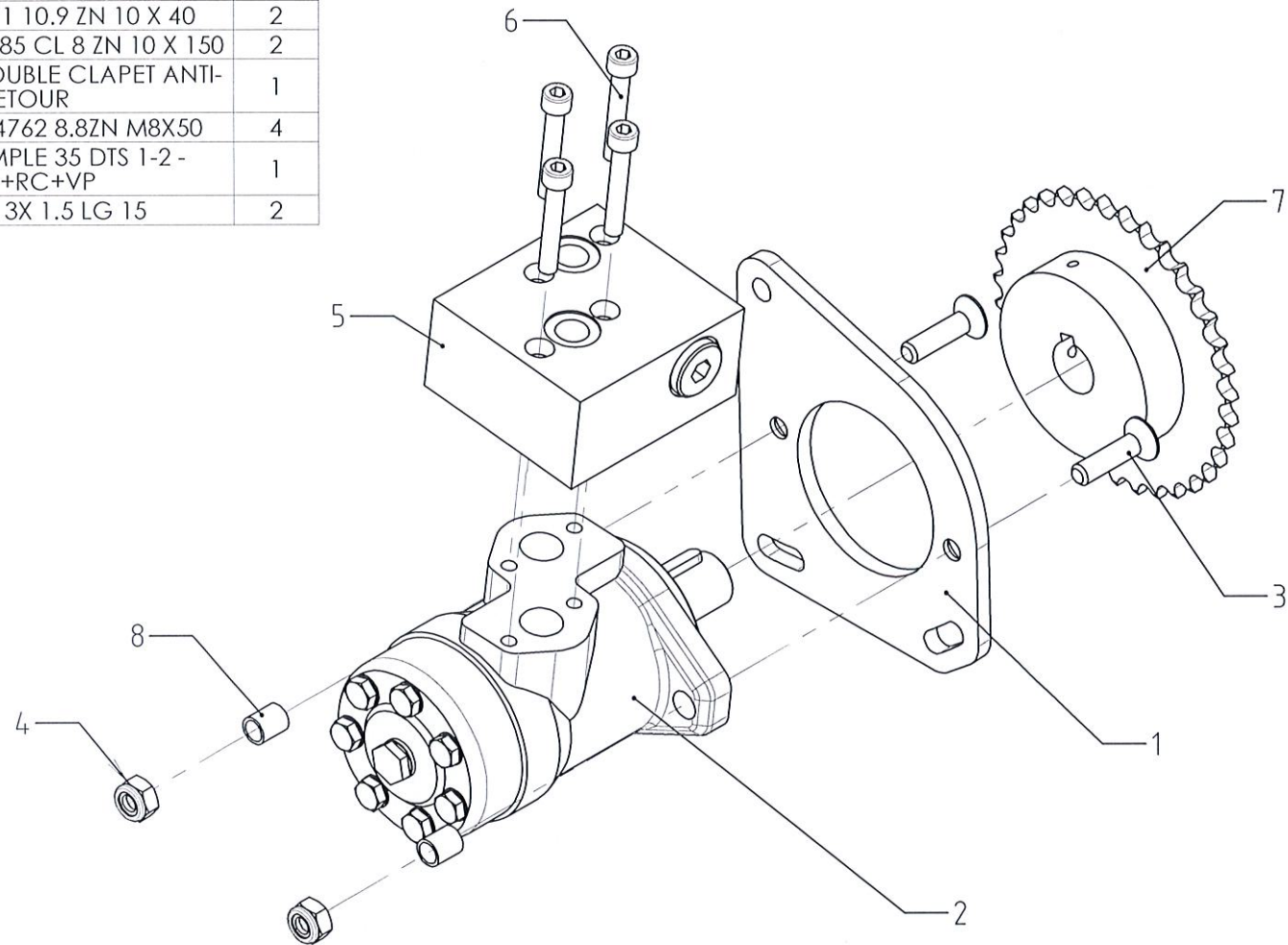

Tolérances générales: ( sauf indications )  
débit +/- 1mm usinage +/- 0.1mm pliage +/- 1° assemblage +/- 1mm



Plan N°:

-

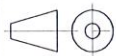

Dess: Admin

Date:  
11-01-2019

Mat.:

Poids: 10.59kg

Format: A4

Traitement de surface:

- Brut

-

Désignation1:

BASE COMMUNE MOTEUR PAIL LAT

Désignation2:

Code Article: E07000029

FEUILLE  
1/1

Ech.: 1:3

Ind.: A

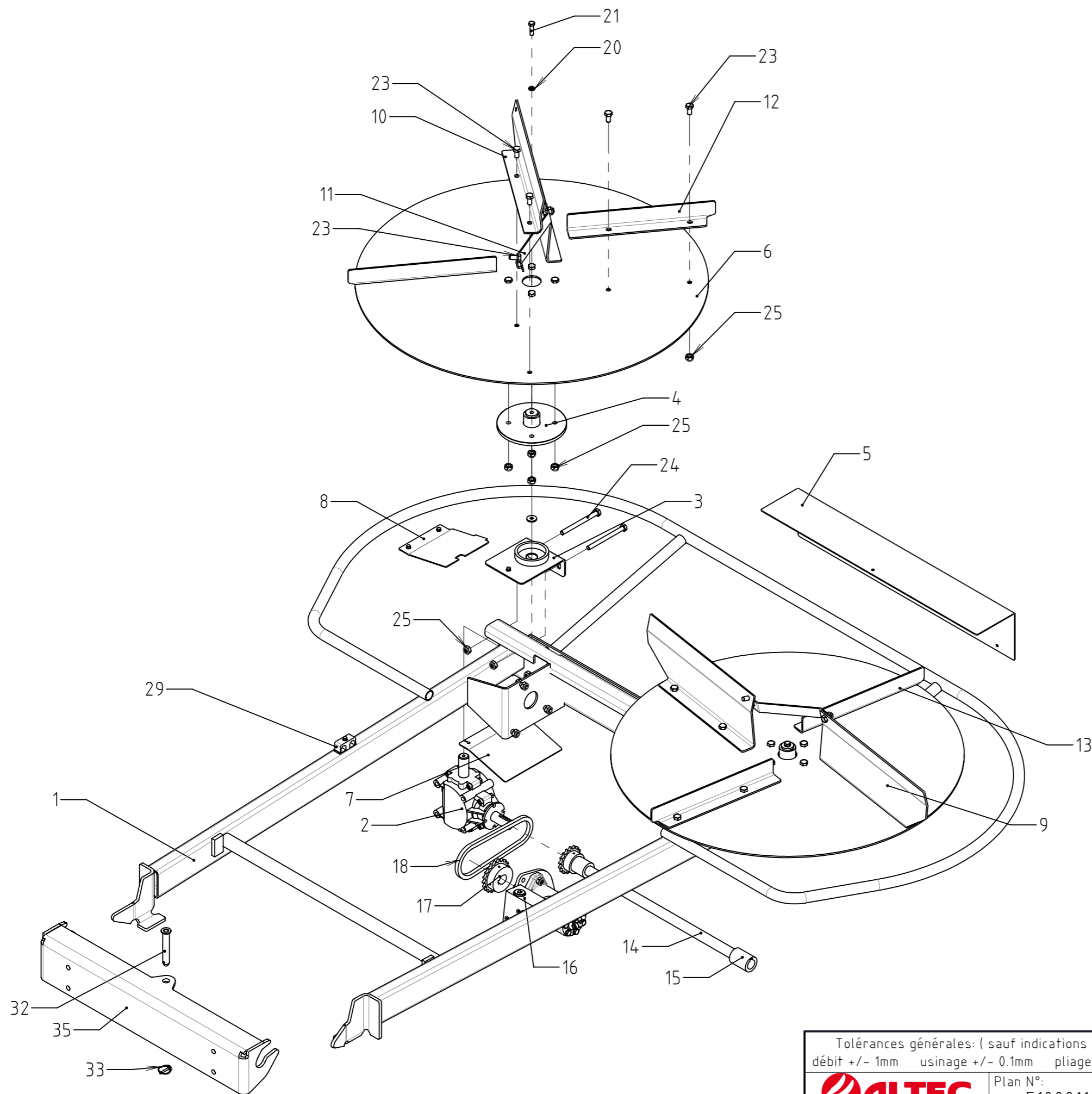

REP.	CODE ARTICLE	DESIGNATION 1	QTE
1	E01000808	CHASSIS PAIL AX DR200P	1
2	C07000002	BOITIER BONDIOLI S1018100R220	2
3	E04000135	CACHE ANTI ENR PAIL AXIAL - REF 36	2
4	E02000055	SUPPORT PLATEAU DISQUES DE PAIL REP 5	2
5	D03000580	DECOUPE LASER L1320 EP. 2 PLIEE	1
6	D01000245	DECOUPE LASER L773 EP.4	2
7	D03000277	DECOUPE LASER L1095 EP.2 PLIEE	1
8	D03000276	DECOUPE LASER L1323 EP.2 PLIEE	1
9	D03000617	DECOUPE LASER L815 EP.4	2
10	P-008877	DECOUPE LASER L815 EP.4 SYM	2
11	D03000372	DECOUPE LASER L1344 EP.3 PLIEE	2
12	P-008878	DECOUPE LASER L816 EP.4 SYM	2
13	D03000618	DECOUPE LASER L816 EP.4 PLIEE	2
14	E05000032	ARBRE LIAISON PAILLEUSE AXIALE	1
15	D02000389	TUBE Ø 40X 8 LG 55	1
16	E07000032	BASE COMMUNE MOTEUR PAIL AXIAL	1
17	C06000030	PIGNON SIMPLE 21 DTS 1-2 - Ø25+RC+VP	1
18	C10000018	CHAINE 12.7 45 MAILLONS+AR	1
19	C08000124	RONDELLE PLATE ZN EPAISSE 8 X 24 X 3	2
20	C08000068	RONDELLE GROWER 127 ZN 8	2
21	C08000335	VIS TH ISO 4017 ZN 8X30 8.8	2
22	C08000304	VIS TH ISO 4017 ZN 10X25 8.8	11
23	C08000303	VIS TH ISO 4017 ZN 10X20 8.8	20
24	C08000190	VIS TH ISO 4014 ZN 10X120 8.8	8
25	C08000031	ECROU FREIN 985 CL 8 ZN 10 X 150	39
26	C08000358	VIS AUTOFOREUSE TH AC ZN 5.5X19	9
27	C08000360	VIS AUTOFOREUSE TH AC ZN 5.5X50	1
28	B05000036	COUDE MALE 08 MALE 1-4 GAZ CO NU	1
29	C12000017	BRIDE DE FIX FLEXIBLE 3-8	1
30	E03001912P	GUIDE FLEXIBLE PAILLEUSE AXIALE	1
31	E01000472	FIX FLEXIBLE PAILL. AXIAL	1
32	E03001161	AXE A RONDELLE BICH 16X100	2
33	C09000009	GOUPILLE CLIP 4.5MM	2
34	B06000177	VANNE 3 VOIES F3-8	1
35	E03001641	SUPPORT PAIL. AXIAL DR200P	1

POUR LES DEMANDES CONCERNANT LES PIGNONS OU LA CHAINE, MERCI DE PRECISER LE NOMBRE DE DENTS OU LE NOMBRE DE MAILLONS

Tolérances générales: ( sauf indications ) débit +/- 1mm usinage +/- 0.1mm pliage +/- 1° assemblage +/- 1mm		
<b>ALTEC</b>		
Dess: Admin	Plan N°: F10001106	Traitement de surface:
Date:	Mat.: Poids: 131.68kg	Brut
	Format: A3	-

Désignation1:  
PAILLAGE AXIAL DR200P

Désignation2:  
PAILLAGE AXIAL DR200P

Code Article: F10001106

FEUILLE  
1/1

Ech.: 1:10  
Ind.: A

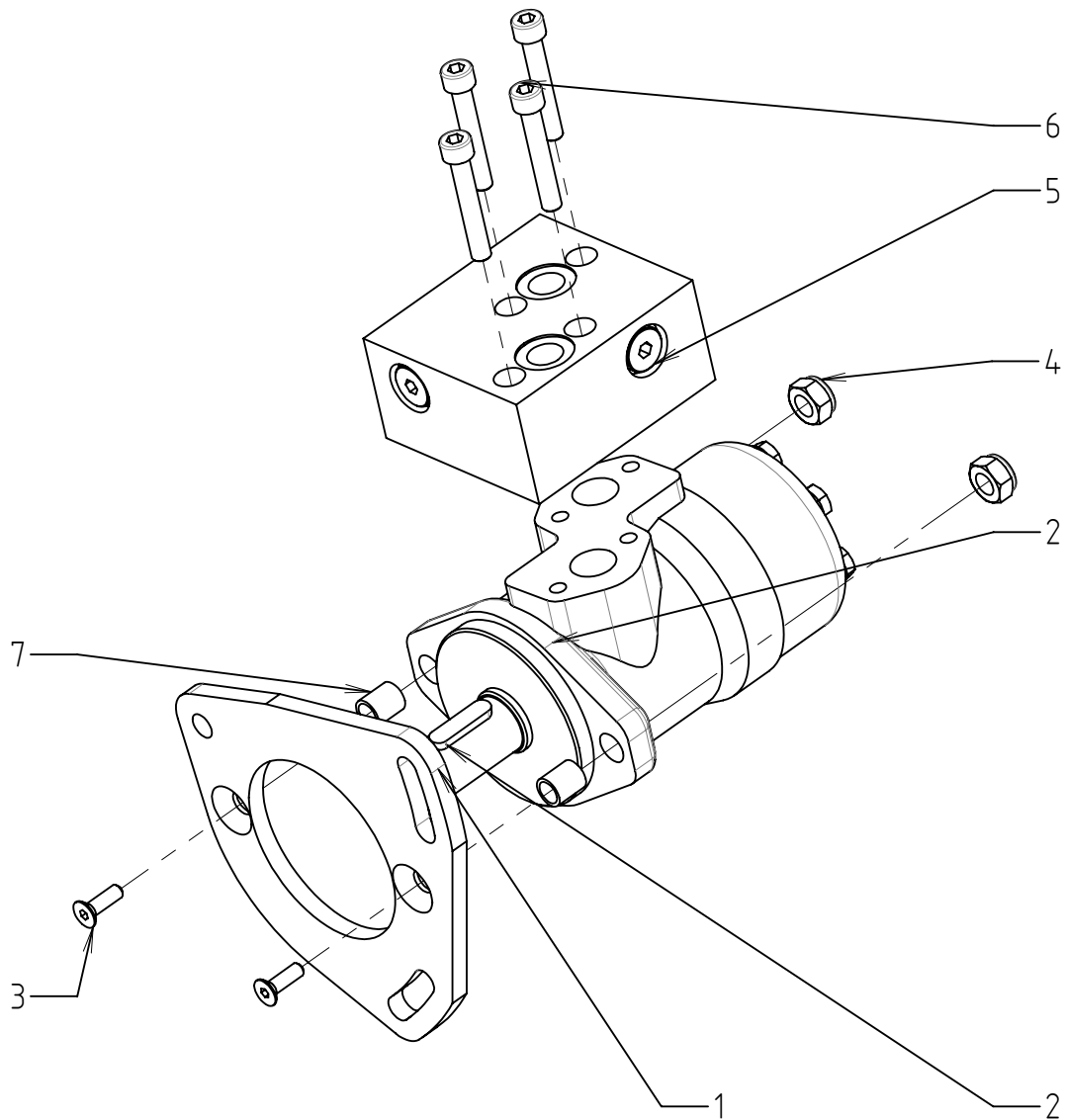

REP.	CODE_ARTICLE	DESIGNATION 1	QTE
1	D02000859	DECOUPE LASER L769B EP.8 FRAISEE	1
2	B01000007	MOTEUR OMP 160	1
3	C08000720	VIS TFHC 7991 10.9 ZN 6 X 20	2
4	C08000031	ECROU FREIN 985 CL 8 ZN 10 X 150	2
5	B06000100	BLOC FORE DOUBLE CLAPET ANTI-RETOUR	1
6	C08000161	Vis CHC ISO 4762 8.8ZN M8X50	4
7	D04000612	TUBE Ø 13X 1.5 LG 15	2

Tolérances générales: ( sauf indications ) débit +/- 1mm usinage +/- 0.1mm pliage +/- 1° assemblage +/- 1mm			Désignation1: BASE COMMUNE MOTEUR PAIL AXIAL	
			Désignation2:	
Dess: Adm	Mat.:	Traitement de surface:		
Date: in 19-09-2014	Poids: 8.43kg	- Brut		
	Format: A4	-		
		Code Article: E07000032	FEUILLE 1/1	Ech.: 1:3 Ind.: A